

# WOOD DESTROYING PESTS AND ORGANISMS INSPECTION REPORT

Building No. 2505	Street Rodman Drive	City Los Osos	Zip 93402	Date of Inspection 04/02/2018	Number of Pages 1 of 6
----------------------	------------------------	------------------	--------------	----------------------------------	---------------------------



A LICENSED PEST CONTROL OPERATOR IS AN EXPERT IN HIS/HER FIELD. QUESTIONS RELATIVE TO THIS REPORT SHOULD BE REFERRED TO HIM/HER.

**Report #: 87979**

Ordered by: Darlene & Ken Kellett 2505 Rodman Drive Los Osos, CA 93402	Property Owner and/or Party of Interest: Darlene & Ken Kellett 2505 Rodman Drive Los Osos, CA 93402	Report sent to: San Luis Obispo Realty Abbie Woodward 441 Marsh Street San Luis Obispo, Ca 93401
---	--	--

COMPLETE REPORT  LIMITED REPORT  SUPPLEMENTAL REPORT  REINSPECTION REPORT  CORRECTED REPORT

General Description: Single story; Single family residence; Stucco exterior; Tile roof; Furnished and occupied.	Inspection Tag Posted: ATTIC
	Other Tags Posted: KEY 6-5-17 LIMITED

An inspection has been made of the structure(s) shown on the diagram in accordance with the Structural Pest Control Act. Detached porches, detached steps, detached decks and any other structures not on the diagram were not inspected.

Subterranean Termites  Drywood Termites  Fungus/Dryrot  Other Findings  Further Inspection   
 If any of the above boxes are checked, it indicates that there were visible problems in accessible areas. Read the report for details on checked items.

Key: 1 = Subterranean Termites    2 = Drywood Termites    3 = Fungus/Dryrot    4 = Other Findings    5 = Unknown Further Inspection

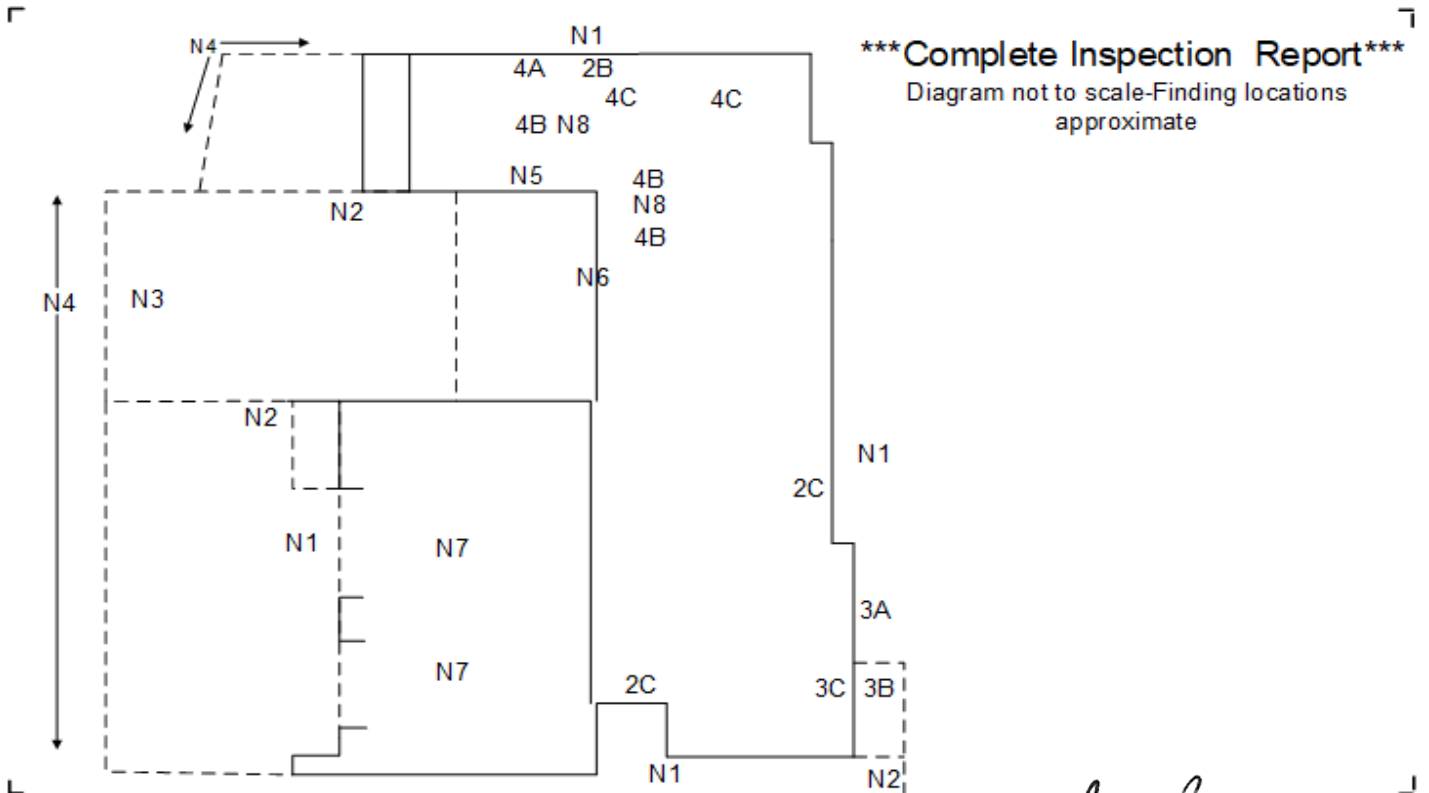

Inspected By:                     Jamie Parkins                     License No.:                     FR28224                     Signature:                     *Jamie Parkins*                    

You are entitled to obtain copies of all reports and completion notices on this property reported to the Structural Pest Control Board during the preceding two years. To obtain copies contact: Structural Pest Control Board, 2005 Evergreen Street, Suite 1500, Sacramento, California, 95815-3831.

NOTE: Questions or problems concerning the above report should be directed to the manager of the company. Unresolved questions or problems with services performed may be directed to the Structural Pest Control Board at (916) 561-8708, (800) 737-8188 or [www.pestboard.ca.gov](http://www.pestboard.ca.gov). 43M-41 (REV. 10/01)

# WOOD DESTROYING PESTS AND ORGANISMS INSPECTION REPORT

Building No.	Street	City	Zip	Date of Inspection	Number of Pages
2505	Rodman Drive	Los Osos	93402	04/02/2018	2 of 6

## **General Comments**

THIS IS A COMPLETE INSPECTION and includes structure(s) of the property as described on page one of this report. The inspection is limited to visible and accessible areas of the structure(s) drawn in diagram space. Other structures of the property were not included in this report. See the statements on the final page of this report for further information as to the scope of this inspection.

NOTE: There was normal storage at the interior of the garage at the time of inspection. Areas covered by normal storage or furnishings were not accessible for visual inspection. Further inspection will be completed upon request after storage has been removed by others. There may be a fee charged for this reinspection.

NOTE: This structure was furnished and occupied at the time of this inspection. Areas covered by normal storage or furnishings were not accessible for visual inspection. Further inspection will be completed upon request after storage has been removed by others. There may be a fee charged for this reinspection.

NOTE: The subfloor of the structure was insulated. The subfloor, portions of the floor joists, and some areas of plumbing were not visible for inspection. If further inspection is desired, we will reinspect the substructure area after the insulation has been removed in areas of concern. Further findings will be issued on a supplemental report and there will be an inspection fee charged.

NOTE: The attic was partially inaccessible due to insulation and low construction in some areas.

This is a separated report which is defined as Section I/Section II conditions evident on the date of the inspection.

"SECTION I" contains items where there is visible evidence of active infestation, infection or conditions that have resulted in or from infestation or infection.

"SECTION II" items are conditions deemed likely to lead to infestation or infection but where no visible evidence of such was found.

"FURTHER INSPECTION" items are defined as recommendations to inspect area(s) which during the original inspection did not allow the inspector access to complete the inspection and cannot be defined as Section I or Section II.

# WOOD DESTROYING PESTS AND ORGANISMS INSPECTION REPORT

Building No.	Street	City	Zip	Date of Inspection	Number of Pages
2505	Rodman Drive	Los Osos	93402	04/02/2018	3 of 6

## Description of Findings

### SECTION: I DRYWOOD TERMITES

Finding: 2A

Evidence of Drywood Termite infestation was found at the exterior, and appears to extend into inaccessible areas of the structure.

Recommendation:

Seal the structure and fumigate with a gas lethal to Drywood Termites (Sulfuryl Fluoride). All occupants and pets must vacate the structure until the fumigation is complete. This company will exercise reasonable caution, but cannot be held responsible for damage to plants, TV antennas or roofing due to the fumigation. Further terms and instructions will be supplied upon request or upon scheduling of the fumigation. Information may also be obtained from the fumigation page on our website at [www.keytermite.com](http://www.keytermite.com)

**\*\*\*Fumigations are guaranteed for 5 years from the date completed\*\*\***

Note:

NOTE: All plant growth at the perimeter of the structure must be cut back to allow 12"-18" of clearance for tarp fumigation. Tree branches must be cut back 4 - 5 feet up from the roof surface if overhanging onto the roof. Plant growth growing on or against the structure which cannot be adequately pulled away from the structure may be covered by the tarp and die as a result of the fumigation process. Additional charges may apply if these preparations are not completed prior to the fumigation date. Labor will be billed at \$45.00 per man hour for preparations.

NOTE: The fumigation process will involve workman walking on the tile roof to install and remove tarps. This may cause damage to some roofing tiles. The extent of damage that may be caused to the roofing tiles is unknown and a specific tile roof release must be obtained from the property owner prior to fumigation. The Fumigation crew will exercise reasonable caution in walking on the roof. If within the initial stages of installing tarps it is determined that the roof tiles may be extensively damaged, we will contact the owner and/or agent for further instruction before continuing. However, Key Termite and Pest Control, Inc. nor its fumigator assume any liability for damages to the roof caused by the fumigation process.

NOTE: Prior to fumigation, the property owner must obtain neighbors permission of properties adjacent to the structure being fumigated.

Price: \$2,650.00

Finding: 2B

Evidence of Drywood Termite infestation was found at the exterior.

Recommendation:

Refer to item 2A for recommendation. Cost included in item 2A.

Note:

Cost included in item 2A.

Price: Included as noted in recommendation.

Finding: 2C

Evidence of Drywood Termite infestation was found at the attic.

Recommendation:

Refer to item 2A for recommendation. Cost included in item 2A.

Note:

Cost included in item 2A.

Price: Included as noted in recommendation.

### FUNGUS/DRYROT

Finding: 3A

Fungus damage was found at the substructure door frame.

Recommendation:

Remove and replace the damaged portions of the substructure door frame as needed to eliminate the fungus infection and damage.

Price: \$133.00

Finding: 3B

Fungus damage was found at the side landing joist framing.

Recommendation:

Remove and replace the damaged portions of the side landing joist framing as needed to eliminate the fungus infection and damage.

Price: \$356.00

# WOOD DESTROYING PESTS AND ORGANISMS INSPECTION REPORT

Building No.	Street	City	Zip	Date of Inspection	Number of Pages
2505	Rodman Drive	Los Osos	93402	04/02/2018	4 of 6

Finding: 3C Fungus damage has occurred to the floor adjacent to the door due to leakage at the door frame.

Recommendation: Remove and replace the damaged portions of the wood floor adjacent to the door. Seal the door frame to control leakage. Additional costs may apply if damage extends into adjacent floor or wall framing. Price does not include replacement of the floor covering. Parties in interest will need to contact a flooring contractor to repair or install new floor covering.

Note: Vinyl for the entrance only.

If vinyl is requested for the entire bathroom the cost will be \$890.00

Price: \$445.00

## **SECTION: II OTHER FINDINGS**

Finding: 4A Moisture damage has occurred to the window sill due to normal condensation.

Recommendation: Repair the damaged window sill as needed. Efforts should be made to control the source of the moisture condensation.

Price: \$267.00

Finding: 4B Moisture damage has occurred to the wood members of the attic sheathing due to a previous moisture condition.

Recommendation: Remove and replace or repair the damaged portions of the attic sheathing as needed.

Price: No Bid offered at this time. Owner should contact appropriate tradesman to complete recommended corrections.

Finding: 4C Loose cellulose debris (wood scraps,paper,etc..) and form boards were found in the substructure area. This may lead to Subterranean Termite infestation.

Recommendation: Remove and dispose of all loose cellulose debris from under the dwelling of such size that will not pass through an ordinary garden rake. Remove and dispose of all form boards, as much as is practical, from the substructure area. Chemically treat the embedded portions that could not be removed with an approved termiticide as a control for Subterranean Termites.

Price: \$178.00

---

**Section I Total: \$3,584.00**  
**Section II Total: \$445.00**

---

**Grand Total: \$4,029.00**

(totals include items priced above only)

# WOOD DESTROYING PESTS AND ORGANISMS INSPECTION REPORT

Building No.	Street	City	Zip	Date of Inspection	Number of Pages
2505	Rodman Drive	Los Osos	93402	04/02/2018	5 of 6

## Informational Items

INFORMATIONAL ITEMS listed below are items where the inspector wishes to inform parties in interest about questionable conditions or report exclusions. These disclosures may be of concern to parties in interest, but did not qualify as a required finding or correction as defined by the Structural Pest Control Act. All parties in interest should satisfy themselves as to these disclosures prior to the close of escrow.

INFORMATIONAL ITEM> N1 : Minor cracks were noted in the exterior stucco. There was no visible indication of adverse condition noted at the interior.

INFORMATIONAL ITEM> N2 : The stucco abutment walls were not inspected. Parties in interest should satisfy themselves as to this condition prior to the close of escrow.

INFORMATIONAL ITEM> N3 : The trellis is not attached and was not included in this report.

INFORMATIONAL ITEM> N4 : The stucco wall was not inspected. Parties in interest should satisfy themselves as to this condition prior to the close of escrow.

INFORMATIONAL ITEM> N5 : A potential moisture condition exists due to a window at the stall shower. The owner should maintain an adequate seal at the window frame and tile to prevent leakage into the wall space.

INFORMATIONAL ITEM> N6 : Dry moisture stains were noted at the door frame. It appears to have been caused by a previous leak. This leak may have already been corrected. It was not possible to determine the activity or cause of leakage at the time of inspection.

INFORMATIONAL ITEM> N7 : There was a moderate amount of storage at the garage interior at the time of inspection. Areas covered by storage were not visible for inspection. If further inspection of inaccessible areas is desired, it should be requested and completed prior to the close of escrow. Storage must be removed by others prior to reinspection. There will be a fee for this reinspection.

INFORMATIONAL ITEM> N8 : Moisture stains were noted at wood members of the attic space and indicates previous leakage. It was not possible to determine the cause or activity of the leakage at the time of inspection. The roofing was not inspected by our company. If inspection of the roof is desired by parties in interest, a qualified Home Inspector and/or licensed Roofing Contractor should be contacted for further evaluation and recommendation.

# WOOD DESTROYING PESTS AND ORGANISMS INSPECTION REPORT

Building No.	Street	City	Zip	Date of Inspection	Number of Pages
2505	Rodman Drive	Los Osos	93402	04/02/2018	6 of 6

- 1.This inspection is limited to the visible and accessible portions of the structure as noted on the diagram only. Although a full diagram may be drawn for reference purposes, all areas may not have been inspected. Please read the entire report to determine the limitations of the inspection. All findings will pertain to infestation and/or infection by wood destroying pests and/or organisms and does not include reference to other structural pests such as, but not limited to; Rats, Mice, Bats, Fleas, Cockroaches, Ants, Etc.. This inspection does not include opinions as to the condition of plumbing, roofing, electrical, gas, heating, air conditioning, or other such structural elements. If such information is desired, we suggest that a qualified Home Inspector be contacted. Inspection of fences is not included in this report unless otherwise stated. The exterior surface of the roof was not inspected. If you want the water tightness of the roof determined, you should contact a roofing contractor who is licensed by the Contractors' State License Board.
- 2.The following areas were not inspected, as indicated in Section #1990, paragraph (j) of the Structural Pest Control Act and Rules and Regulations: Portions of furnished interiors concealed by personal property, inaccessible attics, insulated attics, and portions thereof; the interior of hollow walls; spaces between a floor or porch deck and the ceiling or soffit below; stall showers over finished ceilings: such structural segments as porte-cocheres, enclosed bay windows, buttresses and similar areas to which there is no access without defacing or tearing out lumber, masonry and finished work; built-in cabinet work, floor beneath coverings; areas where storage conditions or locks makes inspection impractical; portions of the structure covered by plant growth. The inspector did not move storage or furnishings during inspection. NEITHER KEY TERMITE AND PEST CONTROL, INC. NOR IT'S EMPLOYEES OR SUBCONTRACTORS MAKES ANY GUARANTEE AGAINST FUTURE OR HIDDEN INFESTATION(S), INFECTION(S), OR ADVERSE CONDITION(S) PRESENT BUT NOT EVIDENT AT THE TIME OF INSPECTION(S). Routine inspection does not include opening windows, opening all exterior doors or inspecting interior of cabinets. Further inspection of these areas may be completed upon request and at additional expense.
- 3.CERTIFICATION applies to visible and accessible areas of the structure observed at the time of original inspection. This certification does not constitute a guarantee that parties in interest will not inherit hidden infestations, infections or adverse conditions. Key Termite and Pest Control, Inc. assumes no liability for such hidden conditions. If a problem is discovered that was not disclosed during our inspections, do not disturb the area. Contact our office immediately to inspect the problem area and allow proper determination. This limitation does not apply to our 5 year guarantee on Fumigation or Full Perimeter Subterrean Termite treatments.
- 4.REINSPECTIONS; "This Company will reinspect repairs done by others within 4 months of the Original inspection. A charge, if any can be no greater than the original inspection fee for each reinspection. The reinspection must be done within ten (10) working days of request. The reinspection is a visual inspection and if inspection of concealed areas is desired, inspection of work in progress will be necessary. Any guarantees must be received from parties performing repairs." Consultation appointments will be made upon request. On site appointments will be billed at a minimum of \$45.00 per appointment. Telephone calls to discuss the report findings are no charge.
- 5.The structure was inspected from the ground level only. Portions of the structure that extend more than 10 feet from the ground level were visually inspected only. Accuracy above this point cannot be guaranteed. Wood members showing visible signs of infestation or infection were pick-tested to determine the nature and extent of the finding. The inspector did not get up on the roof to inspect wood members accessible from the roof.
- 6.NOTICE: The structural Pest Control Board encourages competitive business practices among registered companies. Reports on this structure prepared by various companies should list the same findings (i.e. termite infestations, termite damage, fungus damage, etc.). However, recommendations to correct these findings may vary company to company. You have a right to seek a second opinion from another company.
- 7.NOTICE: The charge for service that this company subcontracts to another person or entity may include the company's charges for arranging and administering such services that are in addition to the direct costs associated with paying the subcontractor. YOU MAY ACCEPT KEY TERMITE AND PEST CONTROL, INC.'S BID OR YOU MAY CONTRACT DIRECTLY WITH ANOTHER REGISTERED COMPANY LICENSED TO PERFORM THE WORK. IF YOU CHOOSE TO CONTRACT DIRECTLY WITH ANOTHER REGISTERED COMPANY, KEY TERMITE AND PEST CONTROL, INC. WILL NOT BE RESPONSIBLE FOR ANY ACT OR OMISSION IN THE PERFORMANCE OF WORK THAT YOU DIRECTLY CONTRACT WITH ANOTHER TO PERFORM.
- 8.This property WAS NOT inspected for the presence or absence of health related molds or fungi. By California Law, we are neither qualified, authorized nor licensed to inspect for health related molds. If you desire information about the presence or absence of health related molds, contact the California Department of Health Related Services. A link may be found in our web site at the following web address <http://www.keytermite.com/mold.html>
- 9.Pesticides are the products Key Termite and Pest Control, Inc. uses to control the target pests listed in your Inspection Report. Pesticides are indispensable tools our industry uses to control disease carrying pests and wood destroying insects, thus protecting your health and property. When properly used, pesticides pose minimal risk to humans or the environment. Your Technician is a State certified applicator whose knowledge is constantly being upgraded through regularly scheduled training sessions. If you have any questions, please call us at our toll free number: 800-548-5599 or write to: Key Termite and Pest Control, Inc., 9605 El Camino Real, P.O. Box 969, Atascadero, CA, 93423. Key Termite and Pest Control, Inc. will not apply any compound not authorized for use in California. Please refer to the Inspection Report above for proposed materials to be used.
- 10.CAUTION: PESTICIDES ARE TOXIC CHEMICALS. Structural Pest Control Operators are licensed and regulated by the Structural Pest Control Board, and apply pesticides which are registered and approved for use by the California Department of Pesticide Regulation and the United States Environmental Protection Agency. Registration is granted when the State finds that based on existing scientific evidence there are no appreciable risks if proper use conditions are followed or that the risks are outweighed by the benefits. The degree of risk depends upon the degree of exposure, so exposure should be minimized. If within 24 hours following an application you experience symptoms similar to common seasonal illness, comparable to the flu, contact Key Termite and Pest Control, Inc. (800-548-5599), your physician, and/or your Poison Control Center. For the Poison Control Center, contact the following: (1-800-876-4766). FURTHER INFORMATION: Contact any of the following: Your pest control operator is Key Termite and Pest Control, Inc., (800-548-5599); for Regulatory Information call the Structural Pest Control Board (916-561-8708), or write 2005 Evergreen Street, Suite 1500, Sacramento, CA, 95815-3831. For answers to your health questions, call the County Health Department; Santa Barbara County Health Dept (805-681-5102); San Luis Obispo County Health Dept (805-781-5544); and for application information, contact the County Agriculture Commissioner; Santa Barbara County Agricultural Commissioner (805-681-5600); San Luis Obispo County Agricultural Commissioner (805-781-5910).
- 11.Under the California Mechanics Lien Law any structural pest control company which contracts to do work for you, any contractor, laborer, supplier or other person who helps to improve your property, but is not paid for his or her work or supplies, has a right to enforce a claim against your property. This means that after a court hearing your property could be sold by a court officer and the proceeds of the sale used to satisfy the indebtedness. This can happen even if you have paid your structural pest control company in full if the subcontractor, laborers or suppliers remain unpaid.
- 12.To preserve their right to file a claim or lien against your property, certain claimants such as subcontractors or material suppliers are required to provide you with a document entitled "Preliminary Notice". Prime contractors and laborers for wages do not have to provide this notice. A Preliminary Notice is not a lien against your property. It's purpose is to notify you of persons who may have a right to file a lien against your property if they are not paid.
- 13.NOTICE: Invoices are due and payable within 30 days. 1.5% per month will be added to account balances beyond 30 days from the date of work completed. This is an annual percentage rate of 18%. (Interest charged pursuant to the Robinson-Patman Act). Interest amounts for balances billed to an Escrow Company as a course of a Real Estate sale will be waived up to 4 months from the date of work completed so long as the property remains in escrow. Should an Escrow transaction cancel, the full account balance is due and payable upon the Escrow cancellation date.

## WORK ORDER AGREEMENT (PAGE 1 OF 2)

Building No.	Street	City	Zip	Date
2505	Rodman Drive	Los Osos	93402	04/04/18



**P.O. Box 969, Atascadero, CA 93423**  
**800-548-5599 / 805-466-8026 fax**  
**www.keytermite.com / info@keytermite.com**

A LICENSED PEST CONTROL OPERATOR IS AN EXPERT IN HIS/HER FIELD. ANY QUESTIONS RELATIVE TO THIS REPORT SHOULD BE REFERRED TO HIM/HER.

**Report #: 87979**

Ordered by: Darlene & Ken Kellett 2505 Rodman Drive Los Osos, CA 93402	Property Owner and/or Party of Interest: Darlene & Ken Kellett 2505 Rodman Drive Los Osos, CA 93402	Completion sent to: San Luis Obispo Realty Abbie Woodward 441 Marsh Street San Luis Obispo, Ca 93401
---	--	--

**COST FOR WORK RECOMMENDED FOR TERMITE REPORT #: 87979 (please circle desired item numbers)**

SECTION I		SECTION II		SECTION NOT DETERMINED OR FURTHER INSPECTION RECOMMENDED
2A	\$2,650.00	4A	\$267.00	
2B	INCLUDED	4B	NO BID	
2C	INCLUDED	4C	\$178.00	
3A	\$133.00			
3B	\$356.00			
3C	\$445.00			
Total Section I:     \$3,584.00		Total Section II:     \$445.00		

I HEREBY AUTHORIZE KEY TERMITE AND PEST CONTROL, INC. TO PERFORM THE FOLLOWING ITEMS: (please list item numbers below)

---

PLEASE INITIAL HERE \_\_\_\_\_ USE SPACE BELOW TO DESCRIBE FURTHER INSTRUCTIONS:

Thank you for choosing Key Termite and Pest Control for your pest control needs. Feel free to call our office to answer any questions you may have concerning the Inspection Report, the Work to be completed or the Terms of this Contract. PLEASE INITIAL THIS PAGE AND RETURN BOTH PAGES OF THIS AGREEMENT TO OUR OFFICE.

# WORK ORDER AGREEMENT (PAGE 2 OF 2)

Building No.	Street	City	Zip	Date
2505	Rodman Drive	Los Osos	93402	04/04/18

\*\*\*\*\*State law requires that you be given the following information\*\*\*\*\*

CAUTION-PESTICIDES ARE TOXIC CHEMICALS. Structural Pest Control Companies are registered and regulated by the Structural Pest Control Board, and apply pesticides which are registered and approved for use by the California Department of Pesticide Regulation Agency and the United States Environmental Protection Agency. Registration is granted when the State finds that, based on existing scientific evidence, there are no appreciable risks if proper use conditions are followed or that the risks are outweighed by the benefits. The degree of risk depends upon the degree of exposure, so exposure should be minimized." If within 24 hours following application you experience symptoms similar to common seasonal illness comparable to the flu, contact your physician or Poison Control Center and Key Termite and Pest Control, Inc. (800) 548-5599 immediately. For further information contact any of the following;

For health questions: The County Health Department (805) 781-5500  
 For application information: The County Agricultural Commissioner (805) 781-5910  
 For regulatory information: The Structural Pest Control Board, 2005 Evergreen Street, Suite 1500, Sacramento, CA 95815-3831, (916) 561-8700

Prices for structural repair include replacement of damaged wood members visible at the time of inspection only. Structural improvements necessary to upgrade the existing construction to current building code or corrections of hidden conditions exposed during repairs will be completed at additional expense. This company assumes no liability for improper or non compliant structure(s) on which we complete repairs. Parties in interest should contact the county building department and/or qualified home inspector concerning the structures' compliance with building code. The property owner is responsible to pay for all costs associated with building permits and engineering fees needed and is not included in the repair bid. There will also be additional costs if upgrades are required by the local building department prior to or during the course of repairs. These costs should be determined and appropriated by parties in interest prior to the close of escrow. Reasonable effort will be taken to match existing material being replaced with the same or similar type. However, Key Termite and Pest Control Inc. does not guarantee new material will match the existing material. Special order materials may delay the completion of recommended work and certification date. Painted wood members that are replaced by this company (except stained or varnished wood, and redwood decking) will be painted unless otherwise requested and will be billed as quoted in report recommendation. This company makes no guarantee of color match. The buyer or seller is responsible to choose paint color prior to commencement of repairs. Structural repair recommendations not priced above may be completed upon request and will be billed at \$85.00 per hour which will include basic construction materials (doors, windows and redwood deck materials would be additional). Key Termite and Pest Control, Inc. nor its employees or subcontractors assumes no liability for distribution of molds, dusts or other allergens as a result of repairs performed to the property. Parties in interest should contact a Certified Industrial Hygienist for further information and advice prior to commencement of repairs. We will exercise reasonable caution with adjacent plant growth during the completion of repairs, however, neither Key Termite and Pest Control, Inc. nor its employees or subcontractors assumes any liability for damages to adjacent plant growth as a result of the completion of repairs. Prices authorized after 30 days from the date of issuance of the inspection report are void and must be re-bid. Our minimum job fee is \$145.00 (to cover trip costs and completion notice paperwork). If repairs completed total less that \$145.00, we will bill the \$145.00 minimum fee.

Under the California Mechanics Lien Law any structural pest control company which contracts to do work for you, any contractor, subcontractor, laborer, supplier, or other person who helps to improve your property, but is not paid for his or her work or supplies, has a right to enforce a claim against your property. This means that after a court hearing, your property could be sold by a court officer and the proceeds of the sale used to satisfy the indebtedness. This can happen even if you have paid your structural pest control company in full if the subcontractor, laborers, or suppliers remain unpaid. To preserve their right to file a claim or lien against your property, certain claimants such as subcontractors or material suppliers are required to provide you with a document entitled "Preliminary Notice." Prime contractors and laborers for wages do not have to provide this notice. A Preliminary Notice is not a lien against your property. Its purpose is to notify you of person(s) who may have a right to file a lien against your property if they are not paid.

NOTICE: Invoices are due and payable within 30 days. 1.5% per month will be added to account balances beyond 30 days from the date of work completed. This is an annual percentage rate of 18%. (Interest charged pursuant to the Robinson-Patman Act). Interest amounts for balances billed to an Escrow Company as a course of a Real Estate sale will be waived up to 4 months from the date of work completed so long as the property remains in escrow. Should an Escrow transaction cancel, the full account balance is due and payable upon the Escrow cancellation date.

By executing this work authorization contract, customer acknowledges that he or she has been advised of the forgoing and has had the opportunity to consult with a qualified professional.

**UNLESS OTHERWISE STATED IN THE INSPECTION REPORT OR THIS CONTRACT, ALL WORK COMPLETED BY KEY TERMITE AND PEST CONTROL IS GUARANTEED FOR TWO YEARS FROM THE DATE OF COMPLETION AGAINST DEFECTS IN MATERIALS AND/OR WORKMANSHIP. ELIMINATION OF REPORTED WOOD DESTROYING PESTS BY STRUCTURAL FUMIGATION AND "PERIMETER PLUS" SUBTERRANEAN TERMITE TREATMENT IS GUARANTEED FOR FIVE YEARS FROM THE DATE OF COMPLETION.**

BY SIGNING BELOW, I ACKNOWLEDGE THAT I HAVE READ, UNDERSTAND AND AGREE TO THE TERMS OF THIS CONTRACT AND THE REPORT IT REFERS TO.

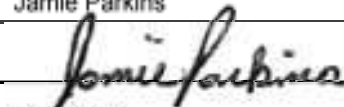
BY OWNER/AGENT/BUYER  PHONE: 805-528-0147  SIGNATURE: _____  PRINT NAME: _____	Key Termite and Pest Control, Inc.  By: <u>Jamie Parkins</u> Signature: <u></u> Lic. #: <u>FR28224</u>
NOTE: WORK WILL NOT COMMENCE UNTIL DELIVERY OF YOUR WOOD DESTROYING PESTS AND ORGANISMS REPORT. FOR DETAILS REGARDING THE ABOVE RECOMMENDATIONS PLEASE REFER TO YOUR INSPECTION REPORT.	





P.O. Box 969, Atascadero, CA 93423  
 800-548-5599 / 805-466-8026 fax  
 www.keytermite.com / info@keytermite.com

# Service Slip / Invoice

INVOICE:	203511
DATE:	04/02/18
ORDER:	203511



**Bill-To:** [43403]  
 Darlene & Ken Kellett  
 2505 Rodman Drive  
 Los Osos, CA 93402

**Work Location:** [43403] 805-528-0147  
 Darlene & Ken Kellett  
 2505 Rodman Drive  
 Los Osos, CA 93402

Work Date	Time	Target Pest	Technician	Time In
04/02/18	12:00 PM		JPARKINS	
Purchase Order	Terms	Last Service	Map Code	Time Out
	NET 30	04/02/18		

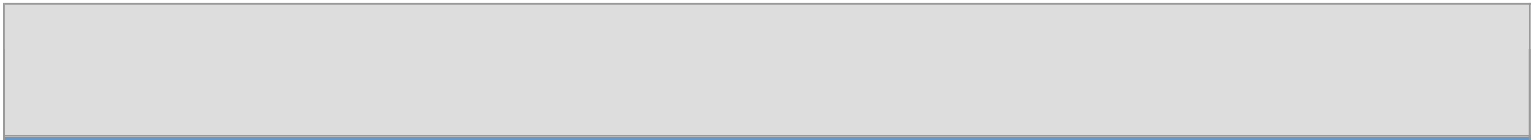

Service	Description	Amount
WDOC	Complete WDO Inspection	\$89.00
<b>SUBTOTAL</b>		\$89.00
<b>TAX</b>		\$0.00
<b>TOTAL</b>		\$89.00
<b>AMT. PAID</b>		\$0.00
<b>BALANCE</b>		\$89.00

\* Charges outstanding over 30 days from the date of service are subject to a 1 1/2% FINANCE CHARGE PER MONTH or annual percentage rate of 18%. Customer agrees to pay accrued expenses in the event of collection.

I hereby acknowledge the satisfactory completion of all services rendered, and agree to pay the cost of services as specified above.

X \_\_\_\_\_  
 CUSTOMER SIGNATURE

**PLEASE PAY FROM THIS INVOICE**