

INVOICE



1115 E. Kimberly Avenue
Anaheim, CA 92801
Ph: (714) 632-3600
Fax: (714) 238-0384
Toll Free: (800) 585-5424



DATE	REPORT #	ESCROW #	PROPERTY LOCATION
05/12/2023	2230953		32307 Conqueror Drive, Rancho Palos Verdes CA 90275

TO: Compass
2141 Rosecrans Ave., Suite 1120
El Segundo, CA 90254
ATTN: Gloria Commiso

05/11/2023	Inspection	\$95.00
------------	------------	---------

Balance Due:	\$95.00
--------------	---------

RETAIN THIS COPY FOR YOUR RECORDS

DUE AND PAYABLE WITHIN RECEIPT

1.5% per month charged on all past due accounts. This is an annual percentage rate of 18%
(Interest charged pursuant to the Robinson-Patman Act)

NOTICE: "Under the Mechanics Lien law, any contractor, subcontractor, laborer, supplier or other person who helps to improve your property but is not paid for his work or supplies, has the right to enforce a claim against your property. This means that after a court hearing, your property could be sold by a court officer and the proceeds of the sale used to satisfy the indebtedness. This can happen even if you have paid your own contractor in full, if the subcontractor, laborer, or supplier remains unpaid."

THANK YOU FOR YOUR BUSINESS

WOOD DESTROYING PESTS AND ORGANISMS INSPECTION REPORT

BUILDING NO. 32307	STREET, CITY, STATE, ZIP Conqueror Drive, Rancho Palos Verdes CA 90275	Date of Inspection 5/11/2023	No. of Pages 10
------------------------------	--	--	---------------------------



Suncrest Exterminating
Termite & Pest Control

Service... We Haven't Forgotten

**1115 E. Kimberly Avenue
Anaheim, CA 92801
Ph: (714) 632-3600
Fax: (714) 238-0384
Toll Free: (800) 585-5424**



Firm Registration No. PR 0474	Report No. 2230953	Escrow No.
Ordered By: Compass 2141 Rosecrans Ave., Suite 1120 El Segundo, CA 90254 Attn: Gloria Commiso (310) 345-4001	Property Owner/Party of Interest Unknown 32307 Conqueror Drive Rancho Palos Verdes, CA 90275	Report Sent To:

COMPLETE REPORT
 LIMITED REPORT
 SUPPLEMENTAL REPORT
 REINSPECTION REPORT

General Description: One story house with a detached garage and a composition roof. Staged	Inspection Tag Posted: Exterior
	Other Tags Posted:

An inspection has been made to the structure(s) shown on the diagram in accordance with the Structural Pest Control Act. Detached porches, detached steps, detached decks and any other structures not on the diagram were not inspected.

Subterranean Termites
 Drywood Termites
 Fungus/Dryrot
 Other Findings
 Further Inspection

If any of above boxes are checked, it indicates that there were visible problems in accessible areas. Read the report for details on checked items.

DIAGRAM NOT TO SCALE

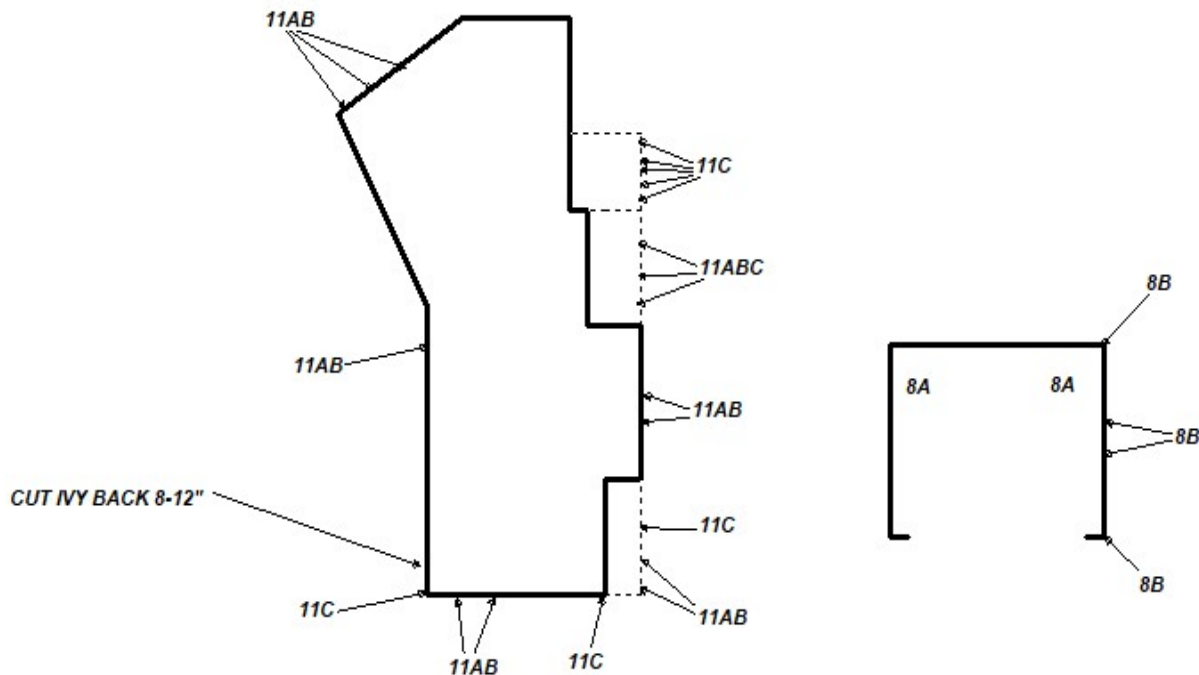

Inspected by Ron Cathcart State License No. FR 54903 Signature 

You are entitled to obtain copies of all reports and completion notices on this property reported to the Structural Pest Control Board during the preceding two years. To obtain copies contact: Structural Pest Control Board, 2005 Evergreen Street, Suite 1500, Sacramento, California 95815.
NOTE: Questions or problems concerning the above report should be directed to the manager of the company. Unresolved questions or problems with services performed may be directed to the Structural Pest Control board at (916) 561-8708, or (800) 737-8188 or www.pestboard.ca.gov. 43M-41 (Rev. 04/2015)

32307	Conqueror Drive, Rancho Palos Verdes CA 90275	5/11/2023	2230953
BUILDING NO.	STREET, CITY, STATE, ZIP	INSPECTION DATE	REPORT NO.

A. Certain areas are recognized by the industry as inaccessible and/or for other reasons not inspected. These include but are not limited to: inaccessible and/or insulated attics or portions thereof, attics with less than 18" clear crawl space, the interior of hollow walls; spaces between a floor or porch deck and the ceiling below; area where there is no access without defacing or tearing out lumber, masonry or finished work; areas behind stoves, refrigerators or beneath floor coverings, furnishings; areas where encumbrances and storage, conditions or locks make inspection impractical, portions of the subarea concealed or made inaccessible by ducting or insulation, area beneath wood floors over concrete, and areas concealed by heavy vegetation. Exterior wood members are probed to inspect for signs of damage. Areas above 10' are visually inspected (unless additional inspection is requested at a cost). Although we make a visual inspection to interior, we do not probe or deface interior areas, unless visible signs of damage are noticed. This inspection is for main structure only and does not include fencing, gates, sheds, any detached structure, wood retaining walls, wood walkways, unless requested.

We assume no responsibility for work done by anyone else, for damage to structure or contents during our inspection, or for infestation, infection, adverse conditions or damage undetected due to inaccessibility or non-disclosure by owner/agent/tenant.

a) Second Story Note: This applies to all areas over 10 feet in height. Due to height restrictions, and safety concerns, all areas over 10' will be visually inspected from ground level for damage wood members. If probing of wood members over 12 feet is requested additional inspection fee's will apply, and be assessed on a case by case basis. Suncrest Exterminating assumes no liability for damages over 10 feet if found at a later date.

B. Slab floor construction has become more prevalent in recent years. Floor covering may conceal cracks in the slab that will allow infestation to enter. Infestations in the walls may be concealed by plaster so that a diligent inspection may not disclose the true condition. These areas are not practical to inspect because of health hazards, damage to the structure; or inconvenience. They were not inspected unless described in this report. We recommend further inspection if there is any question about the above noted areas. Ref: Structural Pest Control Act, Article 6, Section 8516(b), paragraph 1990(i). Amended effective March 1, 1974. Inspection is limited to disclosure of wood destroying pests or organisms as set forth in the Structural Pest Control Act, Article 6, Section 8516(b), Paragraph 1990-1991.

C. A re-inspection will be performed, if requested within four (4) months from date of original inspection, on any corrective work that we are regularly in the business of performing. If CERTIFICATION is required, then any work performed by others must be CERTIFIED by them. There is a \$ 75.00 re-inspection fee.

D. This company is not responsible for work completed by others, recommended or not, including by Owner. Contractor bills should be submitted to Escrow as certification of work completed by others.

E. This report includes findings related to the presence/non-presence of wood destroying organisms and/or visible signs of leaks in the accessible portions of the roof. The inspector did not go onto the roof surface due to possible physical damage to the roof, or personal injury. No opinion is rendered nor guarantee implied concerning the water-tight integrity of the roof or the condition of the roof and roofing materials. If interested parties desire further information on the condition of the roof, we recommend that they engage the services of a licensed roofing contractor.

F. Second story stall showers are inspected but not water tested unless there is evidence of leaks in ceiling below. Ref: Structural Pest Control Rules and Regulations, Sec. 8516G. Sunken or below grade showers or tubs are not water tested due to their construction.

G. During the course of/after opening walls or any previously concealed areas, should any further damage or infestation be found, a supplementary report will be issued. Any work completed in these areas would be at Owner's direction and additional expense.

H. During the process of subterranean slab treatment or replacement it may be necessary to drill holes through ceramic tiles or other floor coverings; These holes will then be sealed with concrete. We will exercise due care but assume no responsibility for cracks, chipping or other damage to floor coverings. We do not re-lay carpeting.

I. We assume no responsibility for damage to any Plumbing, Gas or Electrical lines, etc., in the process of pressure treatment of concrete slabs or replacement of concrete or structural timbers.

32307

Conqueror Drive, Rancho Palos Verdes CA 90275

5/11/2023

2230953

BUILDING NO.

STREET, CITY, STATE, ZIP

INSPECTION DATE

REPORT NO.

J. When a fumigation is recommended we will exercise all due care but assume no responsibility for damage to Shrubby, Trees, Plants, TV Antennas or Roofs. A FUMIGATION NOTICE will be left with, or mailed to the Owner of this property, or his designated Agent. Occupant must comply with instructions contained in Fumigation Notice. During fumigation and aeration, the possibility of burglary exists as it does any time you leave your home. Therefore, we recommend that you take any steps that you feel necessary to prevent any damage to your property. We also recommend that you contact your insurance agent and verify that you have insurance coverage to protect against any loss, damage or vandalism to your property. The company does not provide any onsite security except as required by state or local ordinance and does not assume any responsibility for care and custody of the property in case of vandalism, breaking or entering.

K. Your termite report and clearance will cover EXISTING infestation or infection which is outlined in this report. If Owner of property desires coverage of any new infestation it would be advisable to obtain a Control Service Policy which would cover any new infestation for the coming year.

L. If you should have any questions regarding this report, please call or come by our office any weekday between 8:00 a.m. and 5:00 p.m. We also provide information about additional services for the control of Household Pests such as Ants and Fleas, etc.

M. Owner/agent/tenant acknowledges and agrees that inspection of the premises will not include any type of inspection for the presence or non-presence of asbestos and that this report will not include any findings or opinions regarding the presence or non-presence of asbestos in, upon or about the premises, we recommend that you contact a contractor specifically licensed to engage in asbestos related work. Further, should we discover the presence of asbestos during our inspection of the premises or should our inspection of the premises cause a release of asbestos dust or particles, owner/agent/tenant shall be solely responsible for the cleanup, removal and disposal of the asbestos and the cost thereof. Owner/agent/tenant hereby agrees to waive any and all claims against this Company which are in any way related to the presence of asbestos on the premises and further agrees to indemnify and hold this company harmless from any and all claims of any nature asserted by any third party, including this Company's employees, which is in any way related to the presence of asbestos on the premises.

N. This wood destroying Pests and Organisms Report DOES NOT INCLUDE MOLD or any mold like condition. No reference will be made to mold or mold like condition. Mold is not a Wood Destroying Organism and is outside the scope of this report as defined by the Structural Pest Control Act. If you wish your property to be inspected for mold or mold like conditions, please contact the appropriate mold professional.

O. NOTICE: The charge for service that this company subcontracts to another registered company may include the company's charges for arranging and administering such services that are in addition to the direct costs associated with paying the subcontractor. You may accept Suncrest Exterminating's bid or you may contract directly with another registered company licensed to perform the work. If you choose to contract directly with another registered company, Suncrest Exterminating will not in any way be responsible for any act or omission in the performance of work that you directly contract with another or perform.

P. IMPORTANT NOTE: Under no circumstances should this "Wood Destroying Pest and Organisms Inspection Report: be construed in any way as a guarantee or warranty of the structure. Inspection reports are intended to represent a list of infestations, infections or adverse conditions found after the date of this inspection report by any party will require an additional inspection report with additional findings, recommendations and estimates, if any.

Q. NOTICE: Reports on this structure prepared by various registered companies should list the same findings (i.e. termite infestations, termite damage, fungus damage, etc). However, recommendations to correct these findings may vary from company to company. You have a right to seek a second opinion from another company.

"State law requires that you be given the following information: CAUTION-PESTICIDES ARE TOXIC CHEMICALS. Structural Pest Companies are registered and regulated by the Structural Pest Control Board, and apply pesticides which are registered and approved by use by the California Department of Pesticides Regulation and the United States Environmental Protection Agency. Registration is granted when the state finds that based on existing scientific evidence there are no appreciable risks if proper use conditions are followed or that the risks are out weighted by the benefits. The degree of risk depends upon the degree of exposure, so exposure should be minimize. If within 24 hours following application you experience symptoms similar to common seasonal illness comparable to the flu, contact your physician or poison control center (800) 764 - 7661, (800) 876 - 4766 and your pest control company immediately. For further information, contact any of the following: Suncrest Exterminating (714) 632 -

32307	Conqueror Drive, Rancho Palos Verdes CA 90275	5/11/2023	2230953
BUILDING NO.	STREET, CITY, STATE, ZIP	INSPECTION DATE	REPORT NO.

3600, for health questions - County Health Dept: Orange (714) 834 - 7700; Los Angeles (800) 427 - 8700; San Diego (619) 515 - 6700; Riverside (951) 955 - 3045; San Bernardino (909) 387 - 6280; for application information - County Agricultural Commissioner: Orange (714) 955 -0100; Los Angeles (626) 575 - 5471; San Diego (858) 694 - 8980; Riverside (951) 955 - 3000; San Bernardino (909) 387 - 2105 and for Regulatory Information - The Structural Pest Control Board, 2005 Evergreen St #1500, Sacramento CA 95815 - 3831 (916) 561 - 8708."

R. LIMITED ACCESS ATTICS DEFINITION: Attic was only inspected from access cover, and not accessible, without possibility of causing damage to ceiling below. This includes low pitch roofs with less than 36" of clearance and/or heavily insulated attics making placement of footing difficult. We will not crawl an attic with possibility of breaking through. Items found at later date are not warranty/guaranteed by Suncrest Exterminating.

In accordance with the laws and regulations of the State of California, we are required to provide you with the following information prior to application of termiticides to your property:

For fumigation process, the following fumigant will be used:

Vikane – active ingredients: (99.8% sulfuryl fluoride and chloropicrin)

For treatment process, one of the following chemicals will be used:

Cy-Kick – active ingredients: (Cyflunthrin)

Bora-Care – active ingredients: (Disodium Octaborate Tetrahydrate 40% D.O.T.)

Termidor SC – active ingredients: (Fipronil 9.1%)

Timbor – active ingredients: (Disodium Octaborate Tetrahydrate 98%)

NOTICE: The charge for service that this company subcontracts to another registered company may include the company's charges for arranging and administering such services that are in addition to the direct costs associated with paying the sub-contractor. You may accept Suncrest Exterminating bid or you may contract directly with another registered company. If you choose to contract directly with another registered company Suncrest Exterminating will not in any way be responsible for any act or omission in the performance of work you directly contract with another company to perform.

GUARANTEES: Unless otherwise stated in your WDO report, the guarantees are as follows: Structural fumigations for the control of Drywood termites is guaranteed for four (4) years from the date of completion. Excluding boats, wood piles, patios, gazebos, recreational vehicles, sheds, and any other detached structure not part of the primary residence/building/structure. All excludes items are guaranteed for one year from date of completion. Guarantee applies to current targeted infestations and does not apply to any future infestation. Structural fumigation with a preventative treatment will be guaranteed for five (5) years from date of completion. Includes new infestations. Localized treatments/secondary treatment for the control of drywood/subterranean termites are guaranteed for one (1) year from date of completion, and is limited to areas of original treatment/infestation. Excludes all other areas not treated. Full perimeter subterranean termite treatments are guaranteed for five (5) years from the date of completion. In the event a re-fumigation is required, no compensation will be given for lodging/food/roof repair/plant damage. Wood replacement is guaranteed for one (1) year (excludes cracking/splitting, as these are natural occurrences in wood).

PAINTING: Priming of wood consists of one coat. When paint to match is included in the bid, one coat of paint will be applied. WE DO NOT GUARANTEE AN EXACT MATCH OF PAINT COLOR. Under no circumstances should our paint to match quote be construed as a complete/professional paint job. We recommend you contact a licensed painter for a complete structure paint job. **OWNER MUST SUPPLY PAINT PRIOR TO COMMENCEMENT OF WORK IF PAINTING IS DESIRED.**

WOOD REPAIR/ REPLACEMENT: Due to lumber mill sizes changing over the years, WE CAN NOT GUARANTEE an exact match of lumber sizes. We will install lumber at the current mill sizes. If you would like an exact match, we will special order your lumber at an additional cost to you. All lumber used will have knots and possible splitting. These are natural occurrences in wood and not covered under guarantee by this company. During the course of repairs, it may be necessary to seam wood together, and/or create a new seam. WE WILL NOT REPLACE WOOD THAT HAS BEEN SEAMED TOGETHER. All seams will be filled, but may be noticeable. Wood replacement bid is for visible damage and does not include any additional damage that may be found upon removal of visible damage. All wood replacement will be performed in a workman like manner.

TILE ROOF REPAIRS: Suncrest Exterminating offers tile roof repairs to select tile roofs upon completion of fumigation. Please ask your sales/inspector if your tile roof can be repaired by Suncrest Exterminating. If repair is available, upon completion of fumigation, an inspection of roof will be done for \$ 95.00 (to be applied to repair cost) and a cost to repair will given, valid for 45 days. Minimum cost to repair is \$ 350.00. Repair of broken roof tiles does not guaranteed roof against future leakage. Roof paper/felt that is old may be deteriorated and need additional repairs.

PAYMENTS: All payments are due and payable upon completion of work performed. Invoices past 30 days are subject to a 1

32307

Conqueror Drive, Rancho Palos Verdes CA 90275

5/11/2023

2230953

BUILDING NO.

STREET, CITY, STATE, ZIP

INSPECTION DATE

REPORT NO.

1/2% interest per month (18% annual). In the event a mechanics lien is filed on the property, a \$ 600.00 fee will apply to the outstanding balance as well as the 1 1/2% per month interest. Escrow transaction will be given a 60 day grace period to settle any outstanding balances. In the event the property falls out of escrow or exceeds the 60-day grace period, the balance is due and payable immediately. PAYMENT IS THE RESPONSIBILITY OF THE HOMEOWNER/AGENT/PROPERTY MANAGER ORDERING THE WORK, IF NOT PAID THROUGH ESCROW. WE WILL ENFORCE ALL COLLECTIONS.

By your contracting Suncrest Exterminating you agree to pay reasonable attorney's fees and the \$ 175.00 mechanics lien fee in the event a suit/mechanics lien is required by this company to enforce any terms of this contract, together with the costs of such action, whether or not suit proceeds to judgement.

32307

Conqueror Drive, Rancho Palos Verdes CA 90275

5/11/2023

2230953

BUILDING NO.

STREET, CITY, STATE, ZIP

INSPECTION DATE

REPORT NO.

IF A SEPARATED REPORT HAS BEEN REQUESTED, IT IS DEFINED AS SECTION 1 & SECTION 2 CONDITIONS EVIDENT ON THE DATE OF INSPECTION. SECTION 1 CONTAINS ITEMS WHERE THERE IS EVIDENCE OF ACTIVE INFESTATION, INFECTION OR CONDITIONS THAT HAVE RESULTED IN OR FROM INFESTATION OR INFECTION. SECTION 2 ITEMS ARE CONDITIONS DEEMED LIKELY TO LEAD TO INFESTATION OR INFECTION, BUT WHERE NO VISIBLE EVIDENCE OF SUCH WAS FOUND. FURTHER INSPECTION ITEMS ARE DEFINED AS RECOMMENDATIONS TO INSPECT AREAS WHICH DURING THE ORIGINAL INSPECTION, DID NOT ALLOW THE INSPECTOR ACCESS TO COMPLETE THE INSPECTION AND CANNOT BE DEFINED AS SECTION 1 OR SECTION 2.

1. Subterranean Areas:

LIMITED ACCESS DUE TO CONSTRUCTION

2. Stall Shower:

NOTE: IN ACCORDANCE WITH TITLE 16- CHAPTER 19- SECTION 1991- PARAGRAPH 12 OF THE STRUCTURAL PEST CONTROL ACT, THE UPSTAIRS STALL SHOWER WAS INSPECTED BUT WAS NOT WATER TESTED. NO VISIBLE CRACKS TO THE PAN, STAINING OF THE CEILING BELOW OR ANY SIGNS OF LEAKAGE WERE NOTED AT THIS TIME. IF INTERESTED PARTIES ARE CONCERNED, UPON REQUEST AND PERMISSION, A WATER TEST WILL BE PERFORMED AND ANY FINDINGS WILL BE LISTED ON A SUPPLEMENTAL REPORT.

3. Foundations:

CONCRETE

4. Porches - Steps:

CONCRETE

5. Ventilation:

ADEQUATE

6. Abutments:

NONE

7. Attic Spaces:

NONE

8. Garages:

2 CAR GARAGE - LIMITED ACCESS DUE TO STORAGE

32307

Conqueror Drive, Rancho Palos Verdes CA 90275

5/11/2023

2230953

BUILDING NO.

STREET, CITY, STATE, ZIP

INSPECTION DATE

REPORT NO.

8. Garages:

ITEM 8A Evidence of drywood termites noted in/at garage as marked 8A on the diagram.

RECOMMENDATION: Fumigation of structure using Vikane* (sulfuryl flouride) gas fumigant (Made in the U.S.A), in conjunction with chloropicrin (warning agent). While all due care will be taken we cannot be responsible for any roof/plant/antennas/ satellite damage during the course of fumigation. Please consult with your inspector to see what possible damage may occur. All fumigations are guaranteed for FOUR years from date of completion. (See page 4 for additional details)

All visible drywood termite pellets noted during the time of a complete inspection will be removed via mask/cover. If inspection was limited/fumigation estimate only, no removal of pellets is included. A complete inspection will be needed and an additional costs will apply.

*** A SIGNED "OCCUPANTS FUMIGATION NOTICE", ACCESS TO PROPERTY, AND ACCESS TO ELECTRICAL POWER MUST BE AVAILABLE BEFORE FUMIGATION CAN BE PERFORMED. ***

*** NOTICE: IT'S THE HOMEOWNERS RESPONSIBILITY TO CONTACT THEIR LOCAL GAS COMPANY TO HAVE GAS TURNED BACK ON AFTER FUMIGATION HAS BEEN COMPLETED. ***

*** FUMIGATION PRICE INCLUDES 30 FUMIGATION BAGS (15 ONCE DOUBLED AS REQUIRED) FOR FOOD/MEDICINES. IF ADDITIONAL BAGS ARE NEEDED, WE CHARGE \$ 25.00 PER 30 BAGS. ***

***** This is a Section 1 Item *****

ITEM 8B Evidence of dryrot damage noted to fascia and rafters as marked 8B on the diagram.

RECOMMENDATION: Replace/reinforce and/or wood fill damaged wood as needed to correct this item. Painting not included. NOTE: While all due care will be exercised, this company cannot warrant/guarantee condition of roofing upon removal/replacement of wood members. (I.e roofing of 2-3 or more layers may not lay flat upon completion.) Repair of this item does not constitute roof repairs and/or certification of condition of roof (refer to roof notation on page 3). NOTE: Upon removal of damaged wood, if infection is extending into inaccessible areas, a supplemental report will be issued, outlining findings, recommendations and additional charges (if any).

NOTE: IF RAIN GUTTERS ARE REMOVED IN ORDER TO PERFORM REPAIRS, NO GUARANTEE IS GIVEN ON CONDITION OF RAIN GUTTERS UPON RE-INSTALLATION BY SUNCREST EXTERMINATING.

***** This is a Section 1 Item *****

9. Decks - Patios:

NONE

10. Other - Interiors:

INSPECTED

32307

Conqueror Drive, Rancho Palos Verdes CA 90275

5/11/2023

2230953

BUILDING NO.

STREET, CITY, STATE, ZIP

INSPECTION DATE

REPORT NO.

11. Other - Exteriors:

INSPECTED

NOTE: THE EAVE STRUCTURE IS INACCESSIBLE FOR PHYSICAL INSPECTION DUE TO THE BOXED IN EAVE CONSTRUCTION. NO VISIBLE SIGNS OF PROBLEMS WERE NOTED AT THIS TIME. NO RECOMMENDATIONS ARE MADE. THIS ITEM IS NOT WARRANTED/GUARANTEED BY THIS COMPANY.

ITEM 11A Evidence of drywood termites noted in/at rafters and fascia as marked 11A on the diagram.

RECOMMENDATION: Fumigation of structure using Vikane* (sulfuryl fluoride) gas fumigant (Made in the U.S.A), in conjunction with chloropicrin (warning agent). While all due care will be taken we cannot be responsible for any roof/plant/antennas/ satellite damage during the course of fumigation. Please consult with your inspector to see what possible damage may occur. All fumigations are guaranteed for FOUR years from date of completion. (See page 4 for additional details)

All visible drywood termite pellets noted during the time of a complete inspection will be removed via mask/cover. If inspection was limited/fumigation estimate only, no removal of pellets is included. A complete inspection will be needed and an additional costs will apply.

*** A SIGNED "OCCUPANTS FUMIGATION NOTICE", ACCESS TO PROPERTY, AND ACCESS TO ELECTRICAL POWER MUST BE AVAILABLE BEFORE FUMIGATION CAN BE PERFORMED. ***

*** NOTICE: IT'S THE HOMEOWNERS RESPONSIBILITY TO CONTACT THEIR LOCAL GAS COMPANY TO HAVE GAS TURNED BACK ON AFTER FUMIGATION HAS BEEN COMPLETED. ***

*** FUMIGATION PRICE INCLUDES 30 FUMIGATION BAGS (15 ONCE DOUBLED AS REQUIRED) FOR FOOD/MEDICINES. IF ADDITIONAL BAGS ARE NEEDED, WE CHARGE \$ 25.00 PER 30 BAGS. ***

***** This is a Section 1 Item *****

ITEM 11B Evidence of drywood termite damage noted to rafters and fascia as marked 11B on the diagram.

RECOMMENDATION: Replace/reinforce and/or wood fill damaged wood as needed to correct this item. Painting not included. NOTE: While all due care will be exercised, this company cannot warrant/guarantee condition of roofing upon removal/replacement of wood members. (I.e roofing of 2-3 or more layers may not lay flat upon completion.) Repair of this item does not constitute roof repairs and/or certification of condition of roof (refer to roof notation on page 3). NOTE: Upon removal of damaged wood, if infection is extending into inaccessible areas, a supplemental report will be issued, outlining findings, recommendations and additional charges (if any).

NOTE: IF RAIN GUTTERS ARE REMOVED IN ORDER TO PERFORM REPAIRS, NO GUARANTEE IS GIVEN ON CONDITION OF RAIN GUTTERS UPON RE-INSTALLATION BY SUNCREST EXTERMINATING.

***** This is a Section 1 Item *****

32307

Conqueror Drive, Rancho Palos Verdes CA 90275

5/11/2023

2230953

BUILDING NO.

STREET, CITY, STATE, ZIP

INSPECTION DATE

REPORT NO.

11. Other - Exteriors:

ITEM 11C Evidence of dryrot damage noted to fascia, rafters and trim as marked 11C on the diagram.

RECOMMENDATION: Replace/reinforce and/or wood fill damaged wood as needed to correct this item. Painting not included. NOTE: While all due care will be exercised, this company cannot warrant/guarantee condition of roofing upon removal/replacement of wood members. (I.e roofing of 2-3 or more layers may not lay flat upon completion.) Repair of this item does not constitute roof repairs and/or certification of condition of roof (refer to roof notation on page 3). NOTE: Upon removal of damaged wood, if infection is extending into inaccessible areas, a supplemental report will be issued, outlining findings, recommendations and additional charges (if any).

NOTE: IF RAIN GUTTERS ARE REMOVED IN ORDER TO PERFORM REPAIRS, NO GUARANTEE IS GIVEN ON CONDITION OF RAIN GUTTERS UPON RE-INSTALLATION BY SUNCREST EXTERMINATING.

***** This is a Section 1 Item *****

32307 Conqueror Drive, Rancho Palos Verdes CA 90275 5/11/2023 2230953
 BUILDING NO. STREET, CITY, STATE, ZIP INSPECTION DATE REPORT NO.

OCCUPANTS CHEMICAL NOTICE

Suncrest Exterminating will use pesticide chemical(s) specified below for the control of wood destroying pests or organisms in locations identified in the Structural Pest Control report as indicated above.

(1) The pest(s) to be controlled:
 ___ SUBTERRANEAN TERMITES ___ FUNGUS or DRY ROT
 ___ BEETLES ___ DRY-WOOD TERMITES ___ OTHER _____

(2) The pesticide(s) proposed to be used and the active ingredient(s).

- A. VIKANE: Sulfuryl Flouride (99.8%) in conjunction with Chloropicrin
- ___ B. CY-KICK: Cyflunthrin
- ___ C. PT - 221L - Cyhalothrin
- ___ D. BORA-CARE: Disodium Octaborate Tetrahydrate (40%) (D.O.T.)
- ___ E. TERMIDOR SC: Fipronil 9.1%
- ___ F. TIMBOR: Disodium Octaborate Tetrahydrate (98%)
- ___ G. ALPINE: Dinotefuran, N-methyl-N'-nitro-N'[(tetrahydro-3-furanyl)methyl]guanidine (0.025%)

(3) "State Law requires that you be given the following information: CAUTION-PESTICIDES ARE TOXIC CHEMICALS. Structural Pest Control Operators are licensed and regulated by the Structural Pest Control Board, and apply pesticides which are registered and approved for use by the California Department of Pesticide Regulation and the United States Environmental Protection Agency. Registration is granted when the State finds that based on existing scientific evidence there are no appreciable risks if proper use conditions are followed or that the risks are outweighed by the benefits. The degree of risk depends upon the degree of exposure, so exposure should be minimized.

"If within 24 hours following application you experience symptoms similar to common seasonal illness comparable to the flu, contact your physician or poison control center (213) 484 -5151 and your pest operator immediately. (714) 632 - 3600/(800) 585 - 5424 or Med-Net "Hot Line" 1-800-655-7262.

"For further information, contact any of the following: Suncrest Exterminating (714-632-3600 or 1-800-585-5424); for Health Questions - the County Health Department (Orange Co. 714-456-0603, L.A. Co. 800-427-8700, San Bernardino (800) 782-4264, or Riverside (951) 358 -5200; for Application Information - the County Agricultural Commissioner Orange County - 714-955-0100, L.A. County - 626-575-5471, San Bernardino (909) 387 - 2105, and Riverside (951) 955 -3011 and for Regulatory Information - the Structural Pest Control Board 916-561-8700; 2005 Evergreen Street, Suite 1500, Sacramento, California 95815-3831.

NOTICE TO OWNER

Under the California Mechanics' Lien Law any structural pest control company which contracts to do work for you, any contractor, sub-contractor, laborer, supplier or other person who helps to improve your property, but is not paid for his or her work or supplies, has a right to enforce a claim against your property. This means that after a court hearing, your property could be sold by a court officer and the proceeds of the sale used to satisfy the indebtedness. This can happen even if you have paid your structural pestcontrol company in full if the subcontractor, laborers, or suppliers remain unpaid.

To preserve their right to file a claim or lien against your property, certain claimants such as subcontractors or material suppliers are required to provide you with a document entitled "Preliminary Notice". Prime contractors and laborers for wages do not have to provide this notice. A Preliminary Notice is not a lien against your property. Its purpose is to notify you of persons who may have a right to file a lien against your Property if they are not paid. (2/88)

Persons with respiratory or allergic conditions, or others who may be concerned about their health relative to this chemical treatment, should contact their physician concerning occupancy during and after chemical treatment prior to signing this NOTICE.

NO CHEMICAL APPLICATION WILL BE PERFORMED UNTIL SUCH TIME THAT THIS NOTICE IS RETURNED. HAVING READ THE INSTRUCTIONS, I, THE UNDERSIGNED, WILL ACCEPT RESPONSIBILITY FOR ALL THE AFOREMENTIONED.

 OWNER/OCCUPANT DATE

 OWNER/OCCUPANT DATE

-



1115 E. Kimberly Avenue
 Anaheim, CA 92801
 Ph: (714) 632-3600
 Fax: (714) 238-0384
 Toll Free: (800) 585-5424



WORK AUTHORIZATION CONTRACT

Address of Property: 32307 Conqueror Drive, Rancho Palos Verdes CA 90275
 Inspection Date: 5/11/2023
 Report #: 2230953
 Title Co. & Escrow #:

SECTION 1	SECTION 2	FURTHER INSPECTION
8A \$ 2775.00		
8B SEE 11B		
11A SEE 8A		
11B \$ 2960.00		
11C SEE 11B		

We Authorized the Following Section 1 Items to be Performed.	We Authorized the Following Section 2 Items to be Performed.	We Authorized the Following Items for Further Inspection.
8A, 8B, 11A, 11B, 11C		
Proposed Cost Section 1: <u>\$5,735.00</u>	Proposed Cost Section 2: <u>\$0.00</u>	Proposed Cost Fur.Insp.: <u>\$0.00</u>
	Total: <u>\$5,735.00</u>	

NOTE: ALL PRICING IS VALID FOR 30 DAYS ONLY. ALL JOBS OVER \$5000 WILL REQUIRE A \$500 DEPOSIT

NOTICE TO OWNERS/AGENTS: Under California Mechanics Lien Law, any structural pest control company which contracts to do work for you, and the contractor, subcontractor, laborer, supplier, or other person(s) who helps to improve your property, but is not paid for his/her work/supplies has a right to enforce a claim against your property. This means that, after a court hearing, your property could be sold by the court officer and the proceeds of the sale used to satisfy the indebtedness. This can happen even if you have paid your structural pest control company in full, if the subcontractor, laborer, or supplier remains unpaid. To preserve their right to file a claim or lien against your property certain claimants such as contractors or material suppliers are required to provide you a document entitled "**Preliminary Notice.**" A preliminary notice is not a lien against your property. Its purpose is to notify you of persons who may have the right to file a lien against your property if they are not paid.

The total amount of this contract is due and payable upon completion of work, unless otherwise specified. A finance charge computed at a monthly rate of 1.5% of the unpaid balance (annual rate of 18%) will be added to all accounts 30 days past due.

BY YOUR SIGNATURE BELOW: You agree to all of the terms, conditions, and disclaimers of your WDO report (**please read your report in its entirety**), and agree to pay the amount stated on this work authorization contract. We will enforce all of the terms and conditions.

APPROVED AND READ BY:	DATE	ACCEPTED FOR: SUNCREST EXTERMINATING	DATE
-----------------------	------	---	------



1115 E. Kimberly Avenue
Anaheim, CA 92801
Ph: (714) 632-3600
Fax: (714) 238-0384
Toll Free: (800) 585-5424



WORK AUTHORIZATION CONTRACT

Address of Property: 32307 Conqueror Drive, Rancho Palos Verdes CA 90275
Inspection Date: 5/11/2023
Report #: 2230953
Title Co. & Escrow #:

IMPORTANT CUSTOMER INFORMATION - TERMS AND CONDITIONS

NOTICE TO OWNERS/AGENTS: Under California Mechanics Lien Law, any structural pest control company which contracts to do work for you, and the contractor, subcontractor, laborer, supplier, or other person(s) who helps to improve your property, but is not paid for his/her work/supplies has a right to enforce a claim against your property.

INTEREST: The total amount of this contract is due and payable upon completion of work, unless otherwise specified. A finance charge computed at a monthly rate of 1.5% of the unpaid balance (annual rate of 18%) will be added to all accounts 30 days past due.

ESCROW: Only the work specified on this contract is being done at this time due to owner/agents wishes. Any work performed against an existing title escrow will be the financial responsibility of the party ordering the inspection report, in the event of a cancelled title escrow.

BILLING: As a courtesy the title escrow company will be sent a bill upon completion of work that has been authorized by the owner/agent. Escrow transactions will received a 60 day grace period from time of billing. In the event Escrow has not close within the 60 days grace period, the total amount will be due and payable by the person(s) authorizing the work to be performed. ALL OTHER TRANSACTIONS ARE DUE AND PAYABLE UPON COMPLETION.

BY YOUR SIGNATURE BELOW: You agree to all of the terms, conditions, and disclaimers of your WDO report (please read your report in its entirety), and agree to pay the amount stated on this work authorization contract. We will enforce all of the terms and conditions.

I hereby authorize Suncrest Exterminating to perform the following items:

Item #(s)/Section I/SectionII/Optional Bid _____ Total Estimate of item(s): _____

Authorization by Owner/Agent/Management _____ Date _____

Title _____ P.O/Escrow # _____

Phone (Residence) _____ Business _____

Suncrest Exterminating (714) 632 - 3600 Fax (714) 238 - 0384