

**LEGAL DESCRIPTION**

THE LAND REFERRED TO HEREIN BELOW IS SITUATED IN THE CITY OF LOS ANGELES, COUNTY OF LOS ANGELES, STATE OF CALIFORNIA, AND IS DESCRIBED AS FOLLOWS:

A PORTION OF LOT 3, REPLAT OF A PORTION OF THE PROPERTY OF THE LANKERSHIM RANCH LAND AND WATER CO. TRACT, IN THE CITY OF LOS ANGELES, BOOK 66, PAGES 83-85 OF MISCELLANEOUS RECORDS, IN THE OFFICE OF THE COUNTY RECORDER.

APN: 2377-008-001

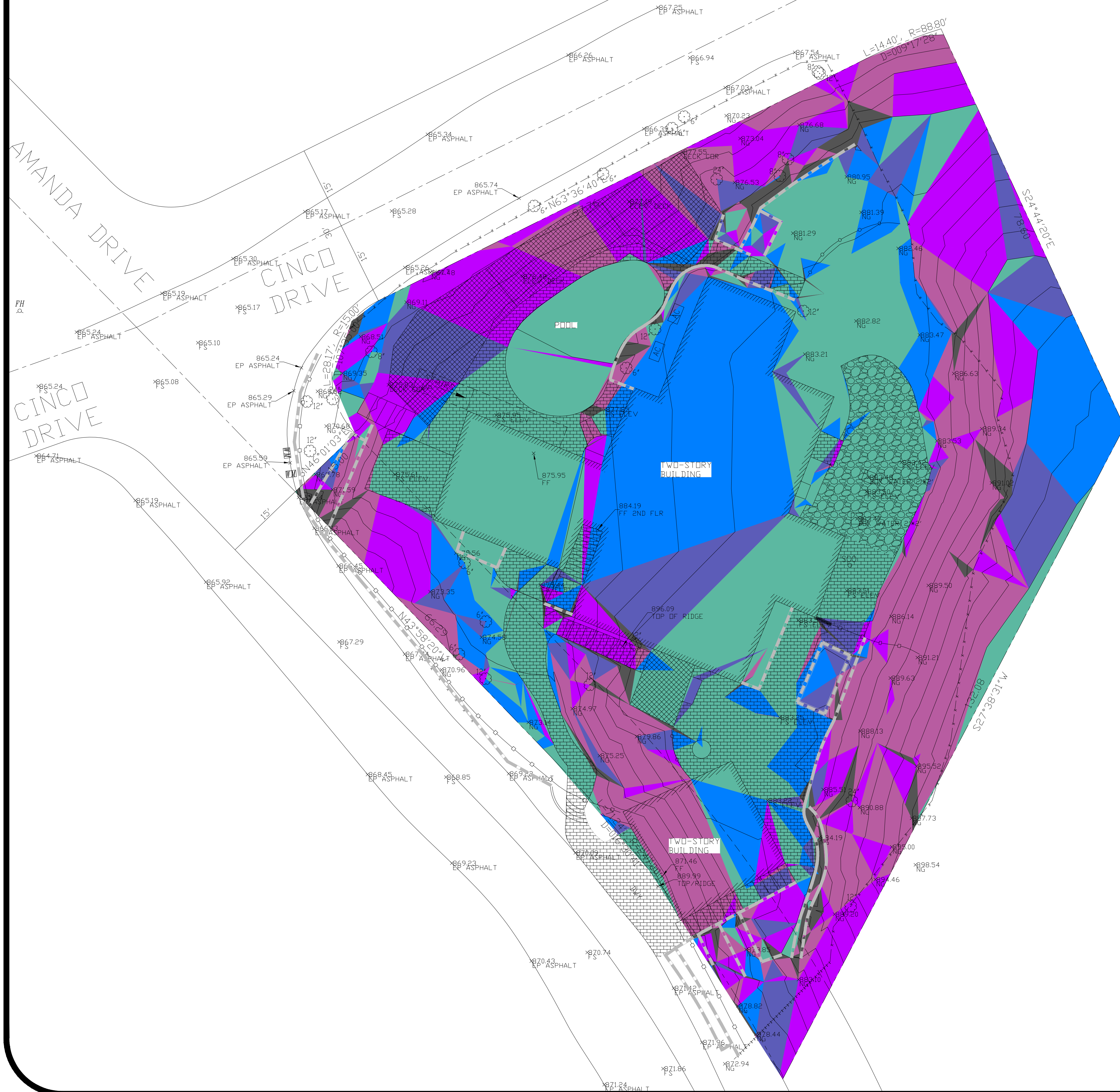

**LEGEND**

AC	AIRCONDITIONING UNIT	---	BOUNDARY LINE
SC	SEWER CLEAN-OUT	12'	TREE
WM	WATER METER	—+—	CONC. BLOCK WALL
PH	FIRE HYDRANT	+	SPOT ELEVATION
DWY	DRIVEWAY	—+—	CHAINLINK FENCE
C/L	CENTER LINE	▨	WOODEN DECK
FS	FINISHED SURFACE	▨	BRICK PAVEMENT
EP	EDGE OF PAVEMENT	▨	STONE PAVEMENT
NG	NATURAL GRADE		

**MAX RESIDENTIAL FLOOR AREA FORMULA (RE15)**

HATCHING	SLOPE BAND (%)	LOT AREA WITHIN EACH SLOPE BAND (SQ. FT.)	FAR FROM ZONE (TABLE - RE15)	MAX RESIDENTIAL FLOOR AREA ALLOWED WITHIN EACH SLOPE BAND	
	0 - 14.99	4696.29	x 0.35 =	1643.70	
	15 - 29.99	2875.15	x 0.30 =	862.55	
	30 - 44.99	1461.52	x 0.25 =	365.38	
	45 - 59.99	2219.37	x 0.20 =	443.87	
	60 - 99.99	3187.57	x 0.15 =	478.14	
	100+	369.00	x 0.00 =	0.00	
MAXIMUM RESIDENTIAL AREA				=	3793.64

**SLOPE DENSITY SURVEY**

PREPARED FOR:  
**YAAQOV RAHLIN**  
 818-451-9971

**NOTES:**  
 1. THE LEGAL DESCRIPTION, BOUNDARIES AND EASEMENT SHOWN HEREON ARE PER RECORD DATA  
 2. MISC. DATA  
 TOTAL PROPERTY AREA: 14,808.90 SQ. FT.

**BENCH MARK:**  
 ASSUMED BENCHMARK  
 ELEVATION=873.00 FT  
 FD SPK/W LS 4318 ON C/L BC OF AMANDA DR

No.	Revision/Issue	Date

**Firm Name and Address**

MOLAI LAND & DESIGN  
 24308 BURBANK BLVD  
 WOODLAND HILLS, CA 91367  
 818-325-9225  
 MOLAI22@YAHOO.COM

**Project Name and Address**

11575 AMANDA DR,  
 STUDIO CITY, CA 91604

Project	6594	Sheet	
Date	7-17-2024		1 OF 1
Scale	1" = 10'		

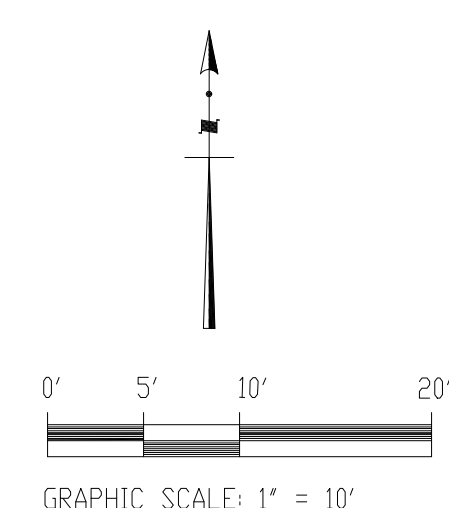



**LEGAL DESCRIPTION**

THE LAND REFERRED TO HEREIN BELOW IS SITUATED IN THE CITY OF LOS ANGELES, COUNTY OF LOS ANGELES, STATE OF CALIFORNIA, AND IS DESCRIBED AS FOLLOWS:

A PORTION OF LOT 3, REPLAT OF A PORTION OF THE PROPERTY OF THE LANKERSHIM RANCH LAND AND WATER CO. TRACT, IN THE CITY OF LOS ANGELES, BOOK 66, PAGES 83-85 OF MISCELLANEOUS RECORDS, IN THE OFFICE OF THE COUNTY RECORDER.

APN: 2377-008-001

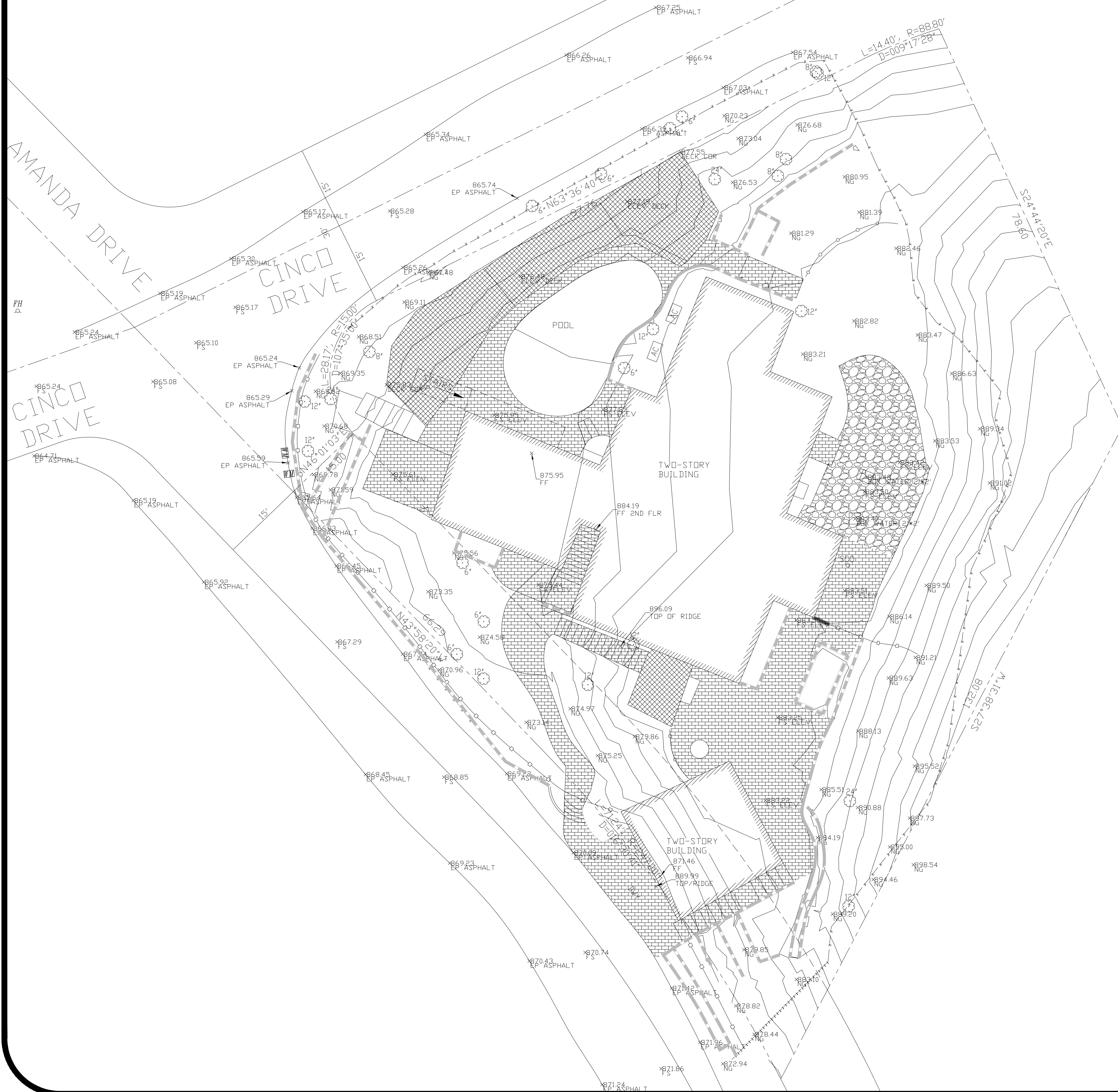

**LEGEND**

AC	AIRCONDITIONING UNIT	---	BOUNDARY LINE
SC	SEWER CLEAN-OUT	12'	TREE
WM	WATER METER	—+—	CONC. BLOCK WALL
PH	FIRE HYDRANT	+	SPOT ELEVATION
DWY	DRIVEWAY	—x—	CHAINLINK FENCE
C/L	CENTER LINE	▨	WOODEN DECK
FS	FINISHED SURFACE	▩	BRICK PAVEMENT
EP	EDGE OF PAVEMENT	○	STONE PAVEMENT
NG	NATURAL GRADE		

**MAX RESIDENTIAL FLOOR AREA FORMULA (RE15)**

HATCHING	SLOPE BAND (%)	LOT AREA WITHIN EACH SLOPE BAND (SQ. FT.)	FAR FROM ZONE (TABLE - RE15)	MAX RESIDENTIAL FLOOR AREA ALLOWED WITHIN EACH SLOPE BAND	
	0 - 14.99	4696.29	x 0.35 =	1643.70	
	15 - 29.99	2875.15	x 0.30 =	862.55	
	30 - 44.99	1461.52	x 0.25 =	365.38	
	45 - 59.99	2219.37	x 0.20 =	443.87	
	60 - 99.99	3187.57	x 0.15 =	478.14	
	100+	369.00	x 0.00 =	0.00	
MAXIMUM RESIDENTIAL AREA				=	3793.64

**SLOPE DENSITY SURVEY**

PREPARED FOR:  
**YAAQOV RAHLIN**  
 818-451-9971

**NOTES:**  
 1. THE LEGAL DESCRIPTION, BOUNDARIES AND EASEMENT SHOWN HEREON ARE PER RECORD DATA  
 2. MISC. DATA  
 TOTAL PROPERTY AREA: 14,808.90 SQ. FT.  
  
**BENCH MARK:**  
 ASSUMED BENCHMARK  
 ELEVATION=873.00 FT  
 FD SPK/W LS 4318 ON C/L BC OF AMANDA DR

No.	Revision/Issue	Date

**Firm Name and Address**

**MOLAI LAND & DESIGN**  
 24308 BURBANK BLVD  
 WOODLAND HILLS, CA 91367  
 818-325-9225  
 MOLAI22@YAHOO.COM

**Project Name and Address**

11575 AMANDA DR,  
 STUDIO CITY, CA 91604

Project	6594	Sheet	
Date	7-17-2024		1 OF 1
Scale	1" = 10'		

